



STE NOUVELLE DE COUPE INDUSTRIELLE  
الشركة الجديدة للفصالة الصناعية



**SIÈGE SOCIAL**

Z.I.Megrine lot SSMT N°23  
Tunis - Tunisie



**USINE**

Z.I.Thniya - Route de Gabes Km 9.5  
Sfax - Tunisie



**FAX**

(+216) 74 289 704



**TÉL**

(+216) 74 289 803 - (+216) 74 289 703



**EMAIL**

sn-ci@gnet.tn



**SITE WEB**

www.snci-tunisie.com

**SOCIÉTÉ** NOUVELLE  
DE COUPE  
**INDUSTRIELLE**



# TÔLE ONDULÉE CORRUGATED SHEET



Tôle ondulée  
Corrugated sheet

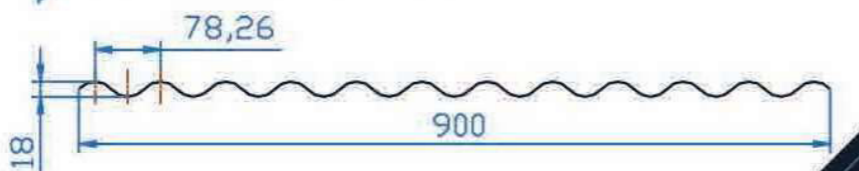

# PANNE C ET Z C AND Z PURLINS

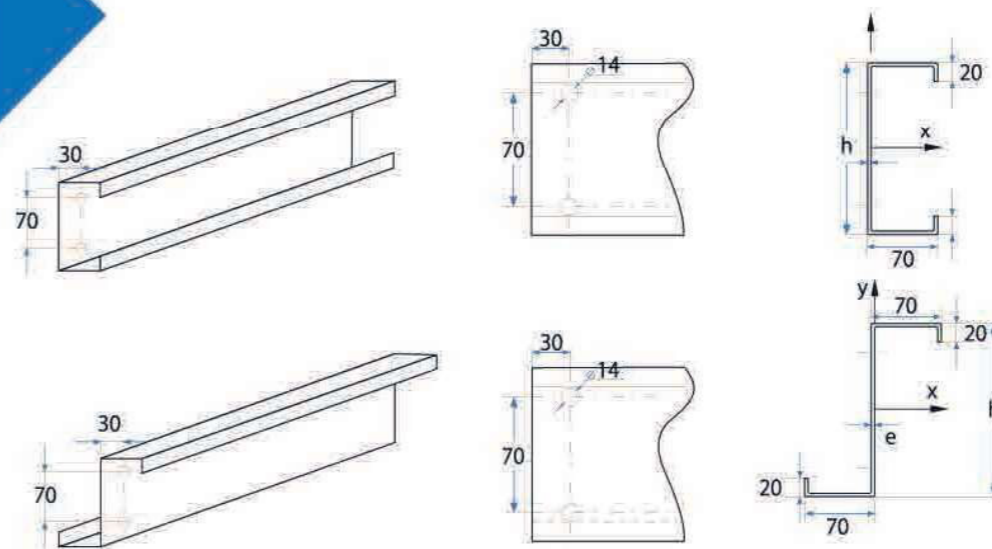

# LAMES DE RIDEAUX BLADES CURTAINS

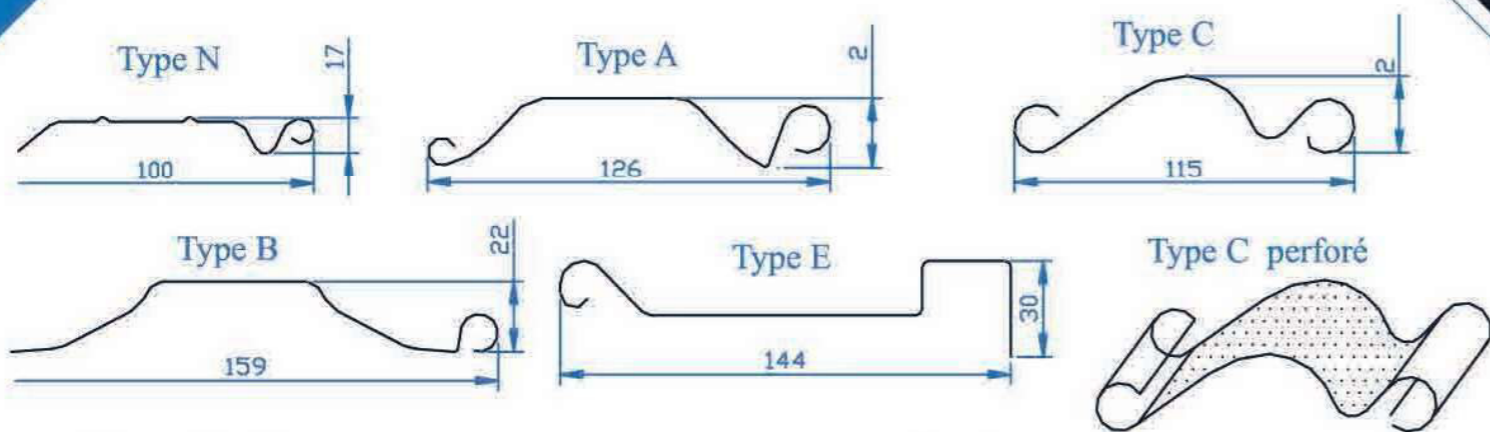

Profil perforé



Lame finale



e (mm)	h (mm)	Poids (Kg/ml)	Ix (Cm)	Ix/v (Cm3)	Ix (Cm)	Iy (Cm3)	Iy/V (Cm3)	Iy (Cm)
2,00	80	3,069	56,16	14,04	3,46	77,10	11,17	4,05
2,00	100	4,00	93,13	18,63	4,27	77,10	11,17	3,89
2,00	120	4,32	140,97	23,50	5,06	77,10	11,17	3,74
2,00	140	4,63	200,50	28,64	5,83	77,10	11,17	3,62
2,00	160	4,95	272,50	34,06	6,58	77,10	11,17	3,50
2,00	180	5,26	357,79	39,75	7,31	77,10	11,18	3,39
2,00	200	5,57	457,16	45,72	8,02	77,10	11,18	3,30
2,00	220	5,89	571,40	51,95	8,73	77,10	11,18	3,21
2,00	240	6,20	701,33	58,44	9,42	77,10	11,18	3,12
2,50	80	4,57	68,82	17,20	3,42	94,04	13,68	4
2,50	100	4,97	114,42	22,88	4,24	94,04	13,68	3,84
2,50	120	5,36	173,53	28,92	5,02	94,05	13,68	3,70
2,50	140	5,75	247,13	35,30	5,79	94,05	13,68	3,57
2,50	160	6,14	336,23	42,03	6,53	94,05	13,68	3,46
2,50	180	6,54	441,84	49,09	7,26	94,05	13,68	3,35
2,50	200	6,93	564,94	56,49	7,98	94,06	13,68	3,26
2,50	220	7,32	706,55	64,23	8,68	94,06	13,68	3,17
2,50	240	7,71	867,65	72,30	9,37	94,06	13,68	3,09
3,00	80	5,42	80,95	20,24	3,39	110,10	16,07	3,95
3,00	100	5,89	134,96	26,99	4,20	110,10	16,07	3,79
3,00	120	6,36	205,04	34,17	4,99	110,11	16,07	3,65
3,00	140	6,83	292,41	41,77	5,75	110,11	16,07	3,53
3,00	160	7,30	398,26	49,78	6,49	110,11	16,08	3,41
3,00	180	7,77	523,79	58,20	7,22	110,12	16,08	3,31
3,00	200	8,24	670,20	67,02	7,93	110,12	16,08	3,22
3,00	220	8,71	838,68	76,24	8,63	110,13	16,08	3,13
3,00	240	9,18	1030,45	85,87	9,33	110,13	16,08	3,05